

MALE END VIEW

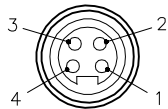

SPECIFICATIONS

HOUSING MATERIAL/COLOR	PBT or NYLON/BLACK
CONTACT MATERIAL/PLATING	BRASS/GOLD
COUPLING NUT MATERIAL/PLATING	DIECAST ZINC/NICKEL
RATED CURRENT [A]	9.0 A (16 AWG), 15.0 A (14 AWG)
RATED VOLTAGE [V]	600 V
MAXIMUM WIRE SIZE	14 AWG
TERMINATION METHOD	SCREW TERMINAL
CABLE GRIP RANGE	6-8mm
TEMPERATURE RATING	-25°C to +85°C (-13°F to +185°F)
PROTECTION CLASS	IP67

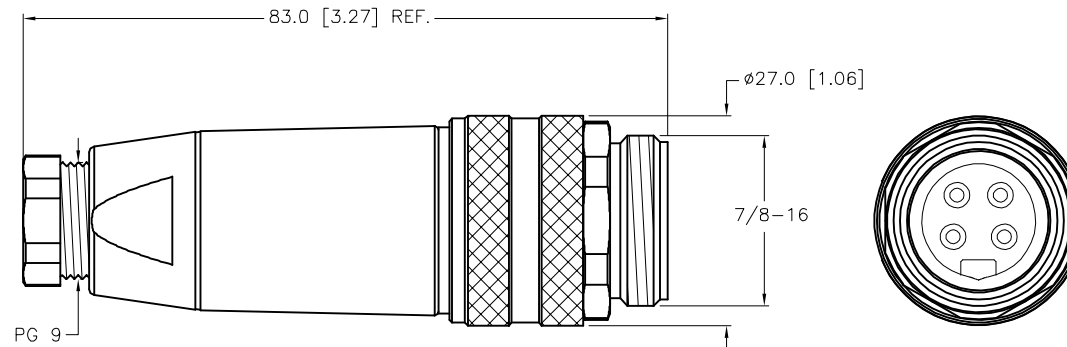

SOURCE DRAWING - FOR REFERENCE ONLY

NOTES:

1. PIN #4 IS A PRE-MATE PIN.

RELATED DOCUMENTS		3RD ANGLE PROJECTION		THIS DOCUMENT IS PROPERTY OF TURCK INC. USE OF THIS DOCUMENT WITHOUT WRITTEN PERMISSION IS PROHIBITED.		TURCK INC High Technology Sensors and Automation Controls 3000 CAMPUS DRIVE MINNEAPOLIS, MN 55441 1-800-544-7769 (612) 553-7300 (612) 553-0708 fax www.turck.com			
1.			ALL DIMENSIONS DISPLAYED ON THIS DRAWING ARE FOR REFERENCE ONLY	DRFT	JB	DATE	08/03/99		
2.				APVD		SCALE	1=1.0	DESCRIPTION	BS 4141-0/9
3.				UNIT OF MEASUREMENT			IDENTIFICATION NO.	REV	
4.				MILLIMETER [INCH]			U6415	F	
MATERIAL		SEE SPECIFICATIONS		CONTACT TURCK FOR MORE INFORMATION		DO NOT SCALE THIS DRAWING		FILE: U6415	SHEET 1 OF 1
FINISH		SEE SPECIFICATIONS							

F	UPDATED CURRENT RATING AND MAXIMUM WIRE SIZE	ER	05/05/22	77602
REV	DESCRIPTION	BY	DATE	ECO NO.